

TELECOM RANGE



Model No. TEL 185F (12 Volts, 183 Ah at 8 hour Rate to 1.75 vpc)
Valve Regulated Lead acid Battery for communications
standby power applications

Innovative Features

- ◆ Completely maintenance free, sealed construction eliminates the need for watering
- ◆ Fully tank formed plates
- ◆ Analytical Grade electrolyte
- ◆ Spill proof / leak proof
- ◆ Valve regulated Max internal pressure 2.5 psi
- ◆ Multi-position usage
- ◆ ABS Case & Cover Flame Retardant meets UL 94 VO requirements
- ◆ Low self discharge
- ◆ FAA and IATA approved as non-hazardous
- ◆ Designed to comply with Bellcore TR-NWT-000766, Bellcore TR-NWT-000909, ANSI T1.330-1997, Telcordia SR 4228, British Standard BS 6290 Part 4, IEC 896 Part 2, Eurobat, DIN 43534
- ◆ UL Recognized, ISO 9001

Ampere Hour Capacity at 77°F (25°C) to 1.75 vpc

Discharge Time in Hrs	1	2	3	4	5	6	7	8	10
Ampere Hour Capacity	130	145	154	162	169	174	179	183	190



Sealed Lead Acid 12 Volt Bloc AGM Range

Specifications

Nominal Voltage		12V	
Nominal Capacity		205 Ah	
Dimensions	Total Height (Inc terminals)	12.6 inches	319.5 mm
	Length	n/a	n/a
	Width	20.9 inches	530 mm
	Weight	4.92 inches	125 mm
		130 lbs	59 Kg



Haze Battery Company Ltd

Characteristics

Capacity 77°F (25°C) to 1.7 vpc	20 hour rate	205 Ah
	10 hour rate	192 Ah
	5 hour rate	170 Ah
	1 hour rate	132 Ah
	15 min rate	80 Ah
	Internal Resistance	3.1 mOhms
Capacity correction for temperature Variations (C20)	104°F (40°C)	102%
	68°F (20°C)	100%
	32°F (0°C)	83%
	5°F (-15°C)	63%
Self Discharge 77°F (25°C)	Capacity after 1 month storage	97%
	Capacity after 3 months storage	93%
	Capacity after 6 months storage	85%
Short Circuit Current 77°F (25°C)	Approx 5500A	
Terminal	Standard	18mm Insert M8 thread
Charging (Constant Voltage)	Float	2.27 - 2.30 vpc (59 - 77°F)

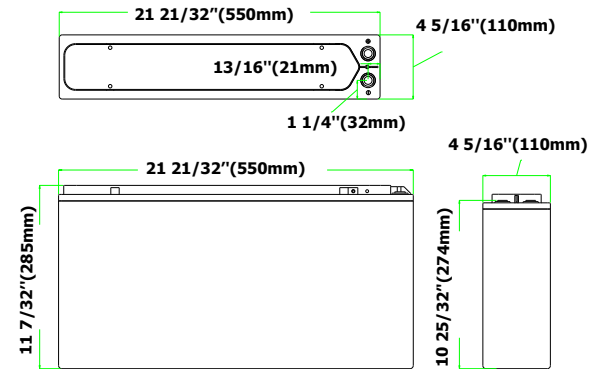

End V per Cell	Ampere Hour at 77°F (25°C)								
	1 hr	2 hr	3 hr	4 hr	5 hr	8 hr	10 hr	12 hr	20 hr
1.85	110.0	128.0	138.0	145.0	151.0	164.0	171.0	174.0	180.0
1.80	125.0	141.0	151.0	159.0	165.0	180.0	186.0	191.0	198.0
1.75	130.0	145.0	154.0	162.0	169.0	183.0	190.0	195.0	202.0
1.70	132.0	146.0	156.0	164.0	170.0	184.0	192.0	197.0	205.0

End V per Cell	Constant Amps Discharge - Amps at 77°F (25°C)								
	1 hr	2 hr	3 hr	4 hr	5 hr	8 hr	10 hr	12 hr	20 hr
1.85	110.00	64.20	45.90	36.30	30.20	20.50	17.10	14.50	9.00
1.80	125.00	70.30	50.20	39.70	33.00	22.40	18.60	15.90	9.90
1.75	130.00	72.60	51.50	40.60	33.70	22.80	19.00	16.20	10.10

Specifications

Design Life	12 Years
Operating Temperature	-4 °F to 122 °F
Grid alloy	Calcium / Tin lead alloy
Plates	Flat Pasted
Separator	Absorbant Glass Mat
Active material	Very high purity lead
Charge Voltage	Float 2.25 - 2.30 VPC @77 °F Cycling 2.35 @77 °F Max. 2.4 VPC Max ripple 0.05C (A)
Electrolyte	Sulphuric acid Analytical grade purity
Venting Valve	EPDM Rubber 1.5 to 2 psi (10.5 - 14 KPa) release pressure. Resealing at 1 psi (7 KPa)
Torque setting	The recommended torque value for all types is 44-62 inch-pounds

Terminal Details

Insert are made from brass with copper, nickel and silver plating giving excellent mechanical, electrical and corrosion resistant properties.

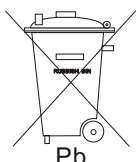
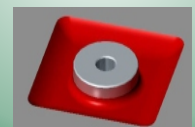

Haze Battery Company keenly encourages environmental awareness; PLEASE follow guidelines for the recycling / disposal of lead.



UL Recognized
Component
MH 20947

