

THE INFORMATION CONTAINED IN THIS DRAWING IS THE SOLE PROPERTY OF NorthStar Battery Company, LLC. ANY REPRODUCTION IN PART OR WHOLE WITHOUT THE WRITTEN PERMISSION OF NorthStar Battery Company, LLC IS PROHIBITED.

REV.	DESCRIPTION	DATE	APPROVED
1	CHANGE ALL DRAWINGS TO NORTHSTAR TITLE BLOCK. ADDED CALLOUT FOR WELDED NUT ON RACK SHELF. REMOVED 3 DIMPLES FROM BACK OF RACK. REMOVED HALF-MOON SLOTS FROM RACK SHELF.	11/30/04	

NSB PT NO. 10RCK0001
 PG. 1 OF 6
 DCN: DWG-514-01-01
 ECO: 450-*S04
 ISSUE DATE: 12-13-2004

PROPRIETARY INFORMATION

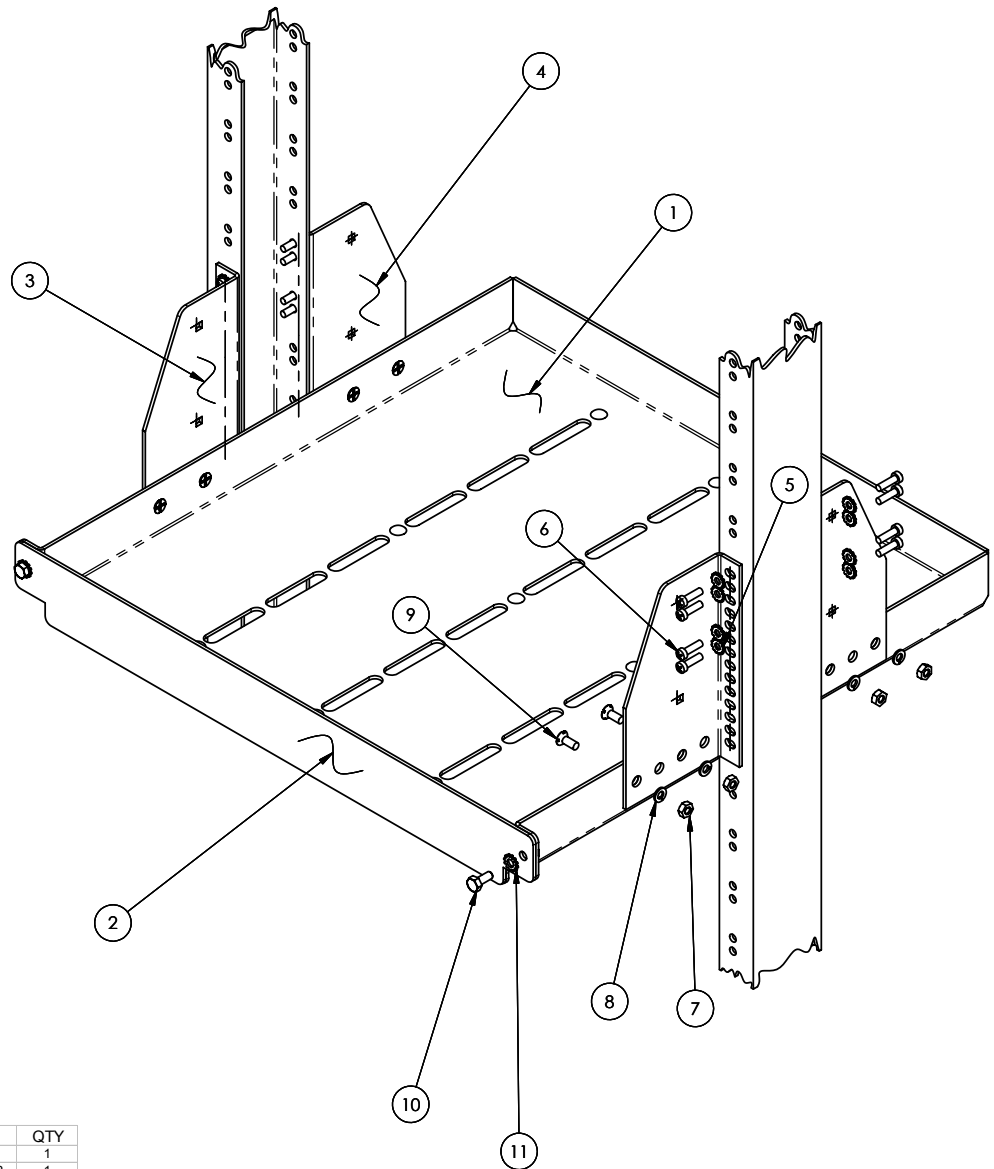

Include a copy of this drawing with each set of parts.

ITEM	DESCRIPTION	QTY
1	23" RACK MOUNT, BATTERY SHELF	1
2	23" RACK MOUNT, BATTERY RETAINER	1
3	RACK MOUNT, RT RACK BRACKET	2
4	RACK MOUNT, LT RACK BRACKET	2
5	WASHER EXT TOOTH #12 ZN	16
6	SCREW PPHH 12-24X3/4 ZN	16
7	NUT HEX ZN 1/4-20	8
8	WASHER SPLIT RING ZN 1/4	8
9	SCREW FHPH 1/40-20 X5/8 ZN	8
10	SCREW HHCS ZN 1/4-20X5/8	2
11	WASHER EXT TOOTH ZN 1/4	2

ITEM NO.	PART OR IDENTIFYING NO.	NOMENCLATURE OR DESCRIPTION	MATERIAL SPECIFICATION	QTY REQD.
UNLESS OTHERWISE SPECIFIED DIMENSIONS ARE IN INCHES. FRACTIONS DECIMALS ANGLES + .XXX+XXX + 1 XXX+XXX		CAD GENERATED DRAWING. DO NOT MANUALLY UPDATE.	APPROVALS	DATE
MATERIAL		NSB-#	NSP ENG	2-14-03
NEXT ASSY USED ON		WASH	MFG ENG	
APPLICATION		DO NOT SCALE DRAWING	DUAL ENG	



23" RACK SHELF ASSY' INSTRUCTION

SCALE: C DWG. NO: RCK0001 SHEET 1 OF 6

THE INFORMATION CONTAINED IN THIS DRAWING IS THE SOLE PROPERTY OF NorthStar Battery Company, LLC. ANY REPRODUCTION IN PART OR WHOLE WITHOUT THE WRITTEN PERMISSION OF NorthStar Battery Company, LLC IS PROHIBITED.

QTY	UOM	NOMENCLATURE OR DESCRIPTION	ITEM NO.
1	EA	23" RACK MOUNT, BATTERY SHELF	1
1	EA	23" RACK MOUNT, BATT. SHELF PLATE	2
2	EA	RACK MOUNT, RT RACK BRACKET	3
2	EA	RACK MOUNT, LT RACK BRACKET	4
8	EA	SCREW FHPH SS 1/4-20X5/8	5
8	EA	NUT HEX SS 1/4-20	6
8	EA	PRESS NUT CLS00420-1	7
2	EA	SCREW PPHF 1/4-20X1/2 SS	8
2	EA	WASHER EXT TOOTH SS 1/4	9

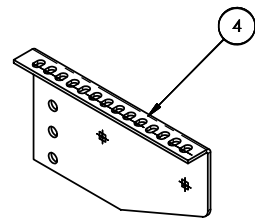
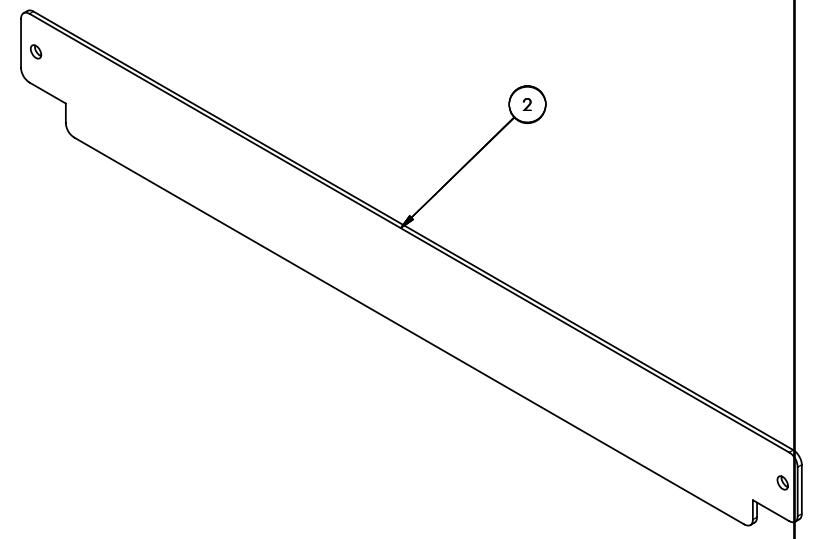
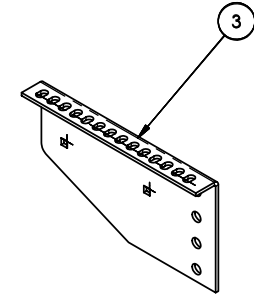
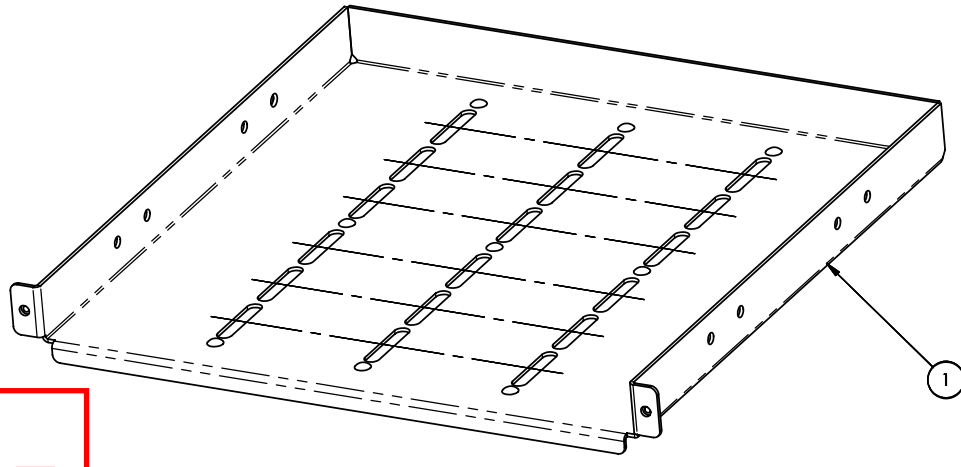

PROPRIETARY INFORMATION

- NOTE:
1. DEBURR & REMOVE ALL SHARP EDGES
 2. PLACE ALL HARDWARE (ITEMS 5,6,7,8&9) INTO A BAG AND SHIP WITH THE SHELF & BRKTS

NSB PT NO. 10RCK0001
 PG. 2 OF 6
 DCN: DWG-514-01-01
 ISSUE DATE: 12-13-2004
 ECO: 450-S04

ITEM NO.	PART OR IDENTIFYING NO.	NOMENCLATURE OR DESCRIPTION	MATERIAL SPECIFICATION	QTY REQD
UNLESS OTHERWISE SPECIFIED DIMENSIONS ARE IN INCHES TOLERANCES ARE: FRACTIONS DECIMALS ANGLES + .XX+ .XX + 1 .XXX+.XXX				
		CAD GENERATED DRAWING. DO NOT MANUALLY UPDATE		
		APPROVALS DATE		
		DRAWN JWH 2-14-03		
		CHECKED		
MATERIAL		NSB-#	REP ENG	
NEXT ASSY USED ON		WJH	MFG ENG	
APPLICATION		DO NOT SCALE DRAWINGS	DUAL ENG	
			SCALE	
			CAD FILE	
			SHEET 2 OF 6	



RACK MOUNT, BATT. SHELF ASSEMBLY

REV: 1

THE INFORMATION CONTAINED IN THIS DRAWING IS THE SOLE PROPERTY OF NorthStar Battery Company, LLC. ANY REPRODUCTION IN PART OR WHOLE WITHOUT THE WRITTEN PERMISSION OF NorthStar Battery Company, LLC IS PROHIBITED.

REV.	DESCRIPTION	REVISIONS	DATE	APPROVED

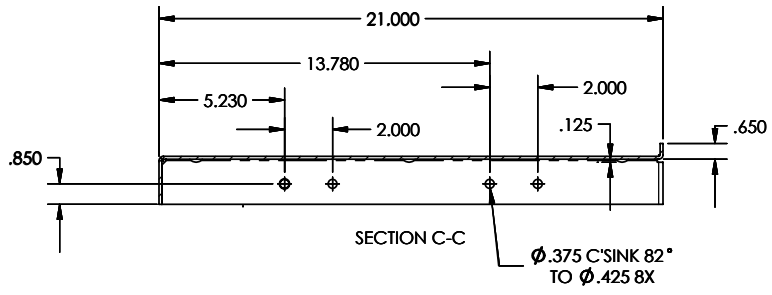
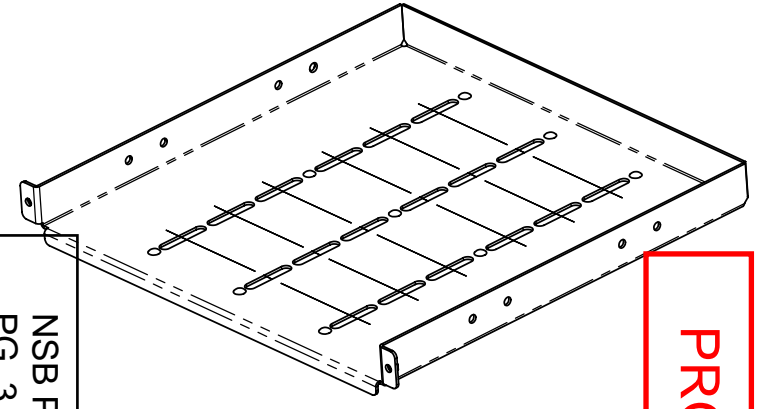
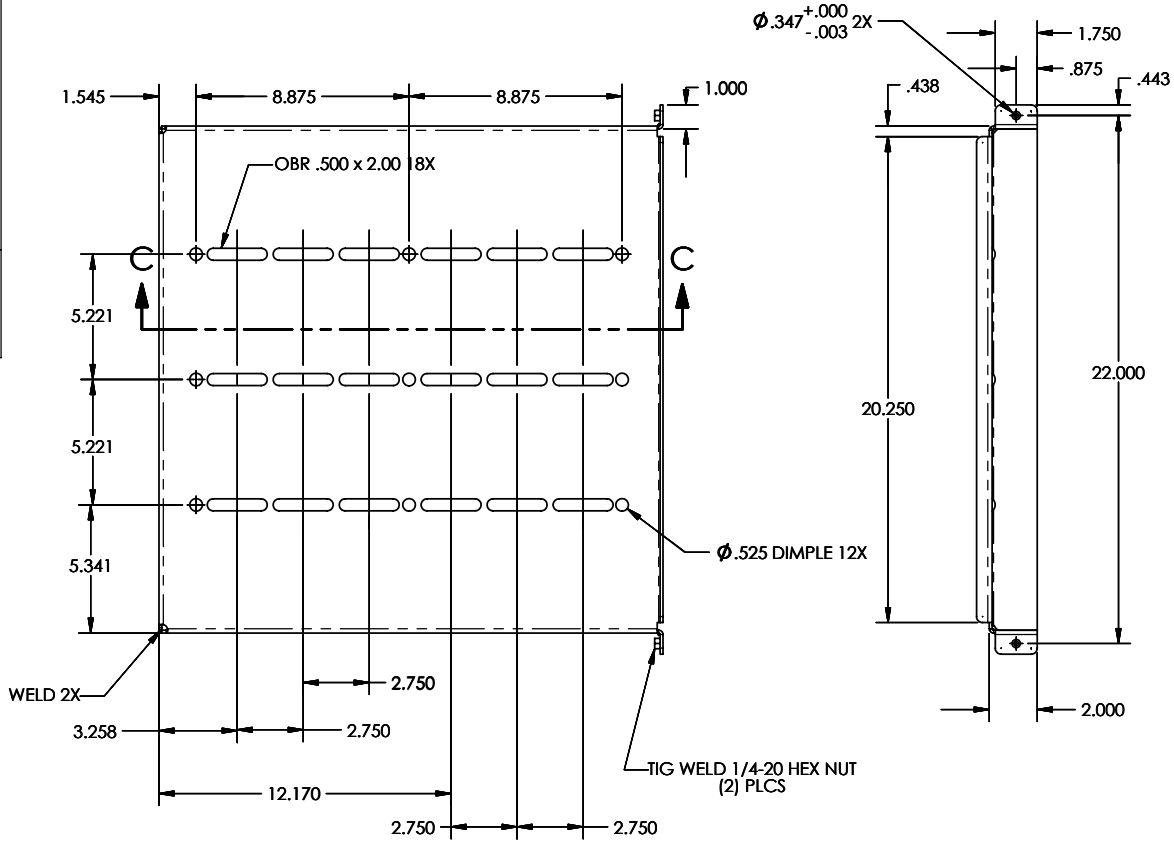

NOTE:
 1. DEBURR & REMOVE ALL SHARP EDGES
 2. USE .060 BEND RADIUS

NSB PT NO. 10RCK0001
 PG. 3 OF 6
 ISSUE DATE: 12-13-2004
 DCN: DWG-514-01-01
 ECO: 450-S04

PROPRIETARY INFORMATION

MATERIAL: 11 GA HRPO
 FINISH: UTILITY GREY POWDER COAT

ITEM NO.	PART OR IDENTIFYING NO.	NOMENCLATURE OR DESCRIPTION	QUANTITY	REVISIONS	DATE	APPROVED

UNLESS OTHERWISE SPECIFIED DIMENSIONS ARE IN INCHES		CAD GENERATED DRAWING. DO NOT MANUALLY UPDATE	
FRACTIONS DECIMALS	ANGLES	APPROVALS	DATE
+ .XXX+XXX	XX° XX' + 1	DRAWN JWH	2-14-03
		CHECKED	
MATERIAL		RESP ENG	
NSB-#		MFG ENG	
NEXT ASSY	USED ON	QUAL ENG	
APPLICATION	DO NOT SCALE DRAWING		

SCALE	DWG. NO.	REV.
	RCK0001	1
CAD FILE	SHEET	OF #
	3	6



23" RACK MOUNT, BATT. SHELF

THE INFORMATION CONTAINED IN THIS DRAWING IS THE SOLE PROPERTY OF NorthStar Battery Company, LLC. ANY REPRODUCTION IN PART OR WHOLE WITHOUT THE WRITTEN PERMISSION OF NorthStar Battery Company, LLC IS PROHIBITED.

REV.	DESCRIPTION	DATE	APPROVED

NSB PT NO. 10RCK0001
 PG. 4 OF 6
 ISSUE DATE: 12-13-2004
 DCN: DWG-514-01-01
 ECO: 450-S04

PROPRIETARY INFORMATION

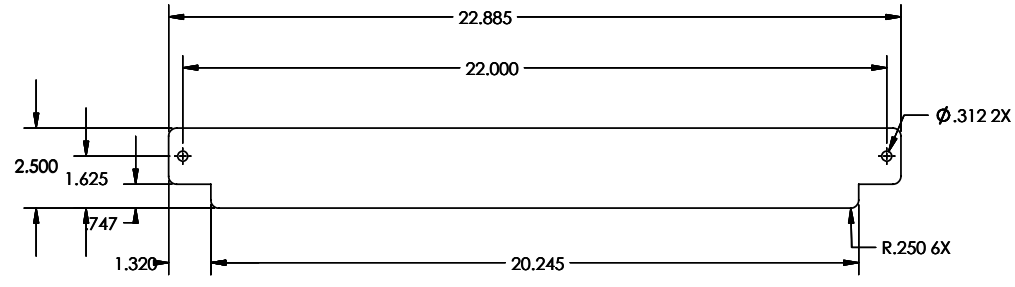

MATERIAL: 11 GA HRPO
 FINISH: UTILITY GREY TOUCH-UP PAINT

NOTE: DEBURR & REMOVE ALL SHARP EDGES

ITEM NO.	PART OR IDENTIFYING NO.	NOMENCLATURE OR DESCRIPTION	MATERIAL SPECIFICATION	QTY REQD.
UNLESS OTHERWISE SPECIFIED DIMENSIONS ARE IN INCHES		CAD GENERATED DRAWING. DO NOT MANUALLY UPDATE		
TOLERANCES ARE:		APPROVALS	DATE	
FRACTIONS DECIMALS ANGLES				
+ .XX+ .XX + 1		DRAWN JWH	2-14-03	
.XXX+XXX		CHECKED		
MATERIAL	---	RESP'NG		
NSB-#	---	MFG'NG		
NEXT ASSY	---	QUAL'NG		
APPLICATION	DO NOT SCALE DRAWING	DUAL'NG		

SCALE	SWG. NO.	REV.
	RCK0001	1
CAD FILE		SHEET 4 OF 6



RACK MOUNT, BATT. SHELF PLATE

THE INFORMATION CONTAINED IN THIS DRAWING IS THE SOLE PROPERTY OF NorthStar Battery Company, LLC. ANY REPRODUCTION IN PART OR WHOLE WITHOUT THE WRITTEN PERMISSION OF NorthStar Battery Company, LLC IS PROHIBITED.

REVISIONS		DATE	APPROVED
REV.	DESCRIPTION		

PROPRIETARY INFORMATION

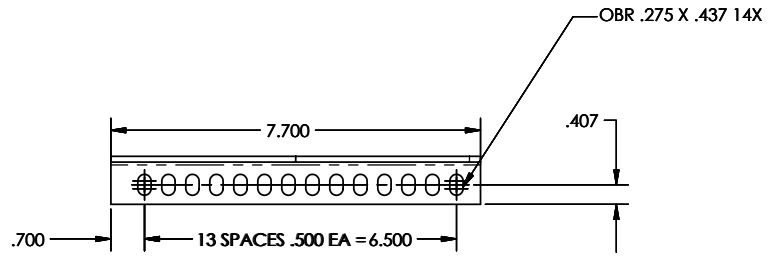
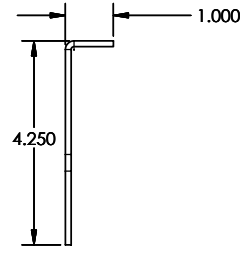
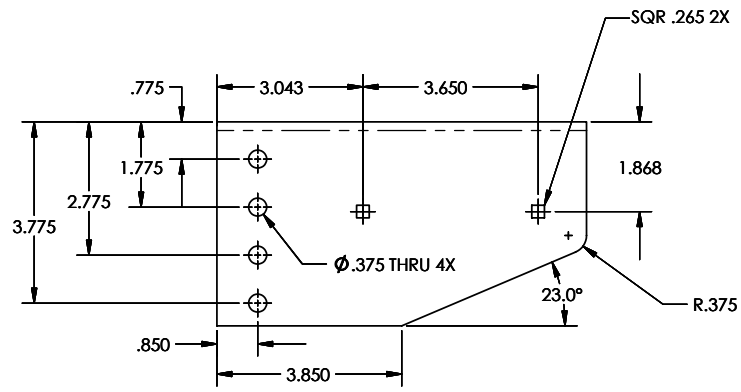

**MATERIAL: 11 GA HRPO
FINISH: UTILITY GREY POWDER**

**NSB PT NO. 10RCK0001
PG. 5 OF 6 ISSUE DATE: 12-13-2004 DCN: DWG-514-01-01
ECO: 450-S04**

NOTE: DEBURR AND REMOVE ALL SHARP EDGES

ITEM NO.	PART OR IDENTIFYING NO.	NOMENCLATURE OR DESCRIPTION	MATERIAL SPECIFICATION	QTY REQD.
UNLESS OTHERWISE SPECIFIED DIMENSIONS ARE IN INCHES		CAD GENERATED DRAWING. DO NOT MANUALLY UPDATE		
TOLERANCES ARE:		APPROVALS	DATE	
FRACTIONS DECIMALS ANGLES		DRAWN JWH	2-14-03	
XXX+ .XX + I				CHECKED
XXX+XXX				
MATERIAL		REP' ENG		
NSB-#		MFG ENG		
NEXT ASSY USED ON		DUAL ENG		
APPLICATION		SCALE	CAD FILE	SHEET 5 OF 6



RACK MOUNT, RT RACK BRACKET

SWG. NO. RCK0001
REV. 1

THE INFORMATION CONTAINED IN THIS DRAWING IS THE SOLE PROPERTY OF NorthStar Battery Company, LLC. ANY REPRODUCTION IN PART OR WHOLE WITHOUT THE WRITTEN PERMISSION OF NorthStar Battery Company, LLC IS PROHIBITED.

PROPRIETARY INFORMATION

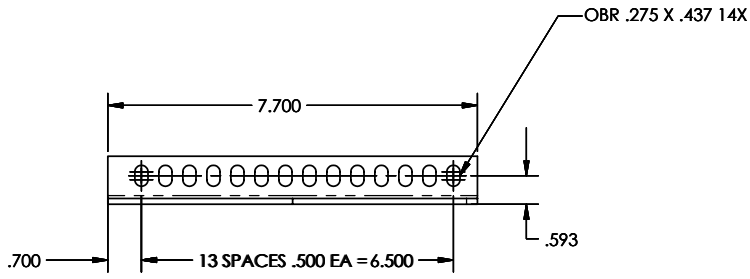
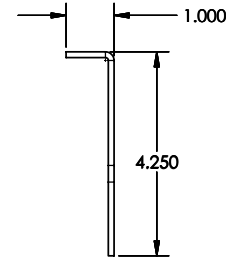
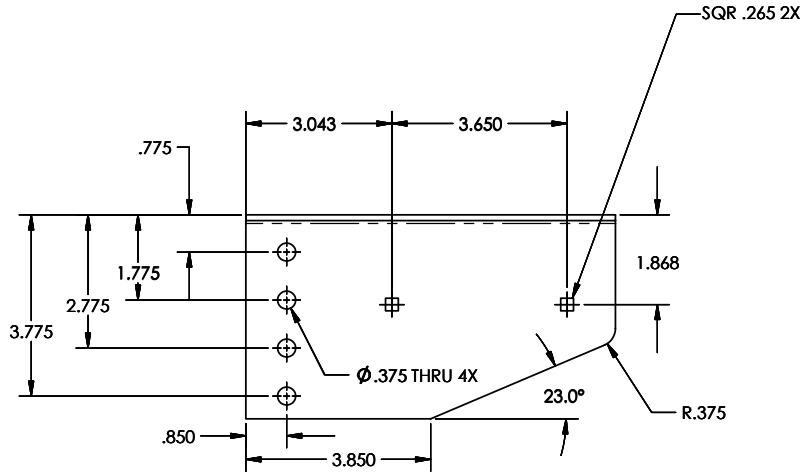

MATERIAL: 11 GA HRPO
FINISH: UTILITY GREY POWDER

NOTE: DEBUR AND REMOVE ALL SHARP EDGES

NSB PT NO. 10RCK0001
 PG. 6 OF 6
 ISSUE DATE: 12/13/2004
 DCN: DWG-514-01-01
 ECO: 450-S04

ITEM NO.	PART OR IDENTIFYING NO.	NOMENCLATURE OR DESCRIPTION	MATERIAL SPECIFICATION	QTY REQD.
UNLESS OTHERWISE SPECIFIED DIMENSIONS ARE IN INCHES		CAD GENERATED DRAWING. DO NOT MANUALLY UPDATE		
TOLERANCES ARE:		APPROVALS	DATE	
FRACTIONS DECIMALS ANGLES		JWH	2-14-03	
+ .XX + .XX + 1		DRAWN		
.XXX+.XXX		CHECKED		
MATERIAL	NSB-#	RESP ENG		
---	---			
NEXT ASSY	USED ON	MFG ENG		
---	---			
APPLICATION	DO NOT SCALE DRAWING	QUAL ENG		
---	---			
SCALE		DWG. NO.		REV.
1		RCK0001		1
CAD FILE		SHEET #		OF #
1		6		6



RACK MOUNT, LT RACK BRACKET