

THE INFORMATION CONTAINED IN THIS DRAWING IS THE SOLE PROPERTY OF Northstar Battery Company, LLC. ANY REPRODUCTION IN PART OR WHOLE WITHOUT THE WRITTEN PERMISSION OF Northstar Battery Company, LLC IS PROHIBITED.

REV.	DESCRIPTION	DATE	APPROVED
1	CHANGED ALL DRAWINGS TO NORTHSTAR TITLE BLOCK ADDED CALLOUT FOR WELDED NUT ON RACK SHELF	11/30/04	
2	ADDED CALLOUT FOR CORNER WELD ON SHEET 5	1/26/05	

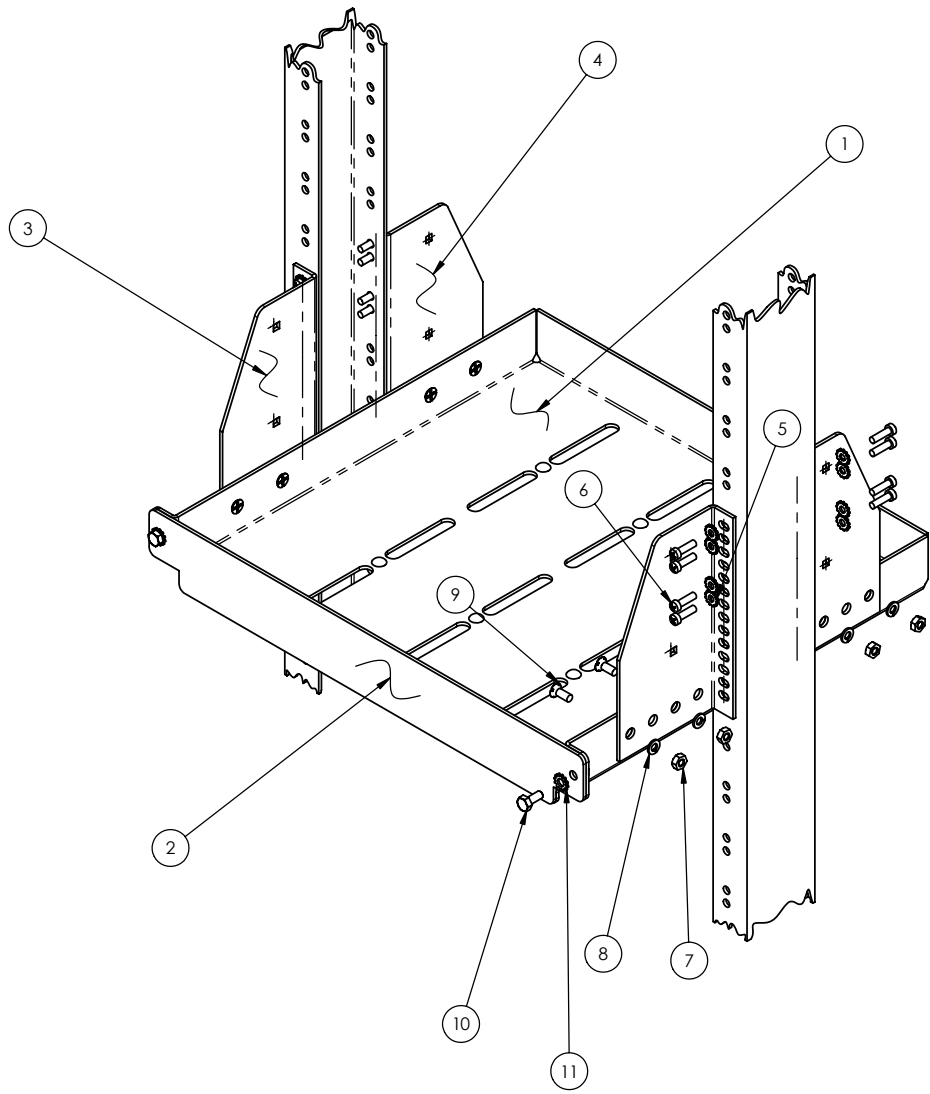

Include a copy of this document with each set of parts.

ITEM	DESCRIPTION	QTY
1	19" RACK MOUNT, BATTERY SHELF	1
2	19" RACK MOUNT, BATTERY RETAINER	1
3	RACK MOUNT, RT RACK BRACKET	2
4	RACK MOUNT, LT RACK BRACKET	2
5	WASHER EXT TOOTH #12 ZN	16
6	SCREW FHPH 12-24X3/4 ZN	16
7	NUT HEX ZN 1/4-20	8
8	WASHER SPLIT RING ZN 1/4	8
9	SCREW FHPH 1/40-20 X5/8 ZN	8
10	SCREW HHCS ZN 1/4-20X5/8	2
11	WASHER EXT TOOTH ZN 1/4	2

PROPRIETARY INFORMATION

Issue Date: 02/07/2005 PG 1 of 6 ECO 479-S04
 NSB PT NO 10RCK0004 DOC CODE: DWG-514-04

ITEM NO.	PART OR IDENTIFYING NO.	NOMENCLATURE OR DESCRIPTION	MATERIAL SPECIFICATION	QTY REQD.
UNLESS OTHERWISE SPECIFIED DIMENSIONS ARE IN INCHES		CAD GENERATED DRAWING. DO NOT MANUALLY RESIZE		
TOLERANCES ARE:		APPROVALS	DATE	
FRACTIONS DECIMALS ANGLES		XXX XX + I	6-4-03	
+ .0004-.0008		DRAWN JWH		
MATERIAL		CHECKED		
NSB-#		REP ENG		
NEXT ASSY USED ON		MFG ENG		
APPLICATION		DUAL ENG		
DO NOT SCALE DRAWING				

19" RACK SHELF ASSY INSTRUCTION

ISS: RCK0004
 SCALE: CAD FILE
 SHEET 1 OF 6

THE INFORMATION CONTAINED IN THIS DRAWING IS THE SOLE PROPERTY OF NorthStar Battery Company, LLC. ANY REPRODUCTION IN PART OR WHOLE WITHOUT THE WRITTEN PERMISSION OF NorthStar Battery Company, LLC IS PROHIBITED.

QTY	UOM	NOMENCLATURE OR DESCRIPTION	ITEM NO.
1	EA	19" RACK MOUNT, BATTERY SHELF	1
1	EA	19" RACK MOUNT, BATT. SHELF PLATE	2
2	EA	RACK MOUNT, RT RACK BRACKET	3
2	EA	RACK MOUNT, LT RACK BRACKET	4
1	EA	19" RACK MOUNT, BATTERY SHELF KIT	

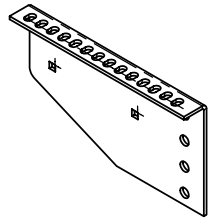
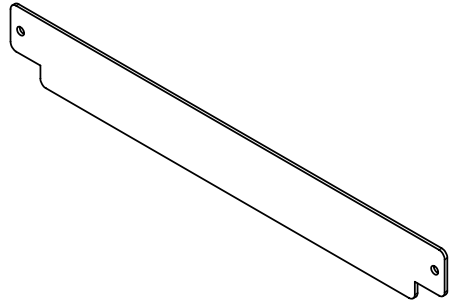
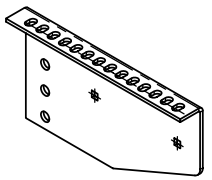
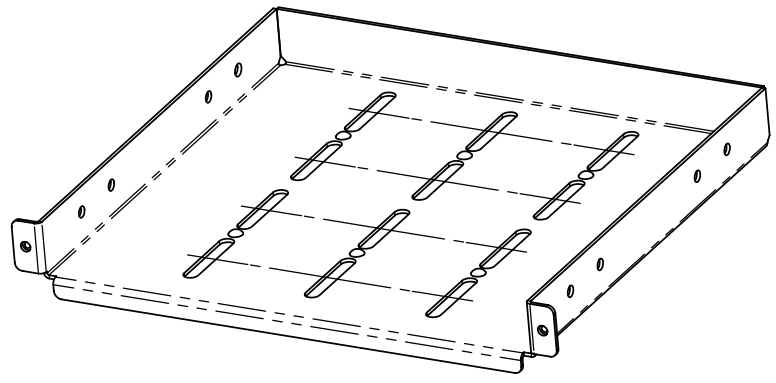

PROPRIETARY INFORMATION

Issue Date: 02/07/2005 PG 1 of 6 ECO 479-S04
 NSB PT NO 10RCK0004 DOC CODE: DWG-514-04

ITEM NO.	PART OR IDENTIFYING NO.	NOMENCLATURE OR DESCRIPTION	MATERIAL SPECIFICATION	QTY REQD.
		UNLESS OTHERWISE SPECIFIED DIMENSIONS ARE IN INCHES FRACTIONS DECIMALS ANGLES XX ⁺ XX ⁻ XX + 1 XXXX-XXXX	CAD GENERATED DRAWING. DO NOT MANUALLY EDIT	
		APPROVALS	DATE	
		DRAWN JWH	6-4-03	
		CHECKED		
	NSB-#	MATERIAL	REP ENG	
	NEXT ASSY	USED ON	MFG ENG	
	APPLICATION	DO NOT SCALE DRAWING	QUAL ENG	
		SCALE	CAD FILE	SHEET 2 OF 6



19" RACK MOUNT, BATTERY SHELF ASSY
 RCK0004

THE INFORMATION CONTAINED IN THIS DRAWING IS THE SOLE PROPERTY OF NorthStar Battery Company, LLC. ANY REPRODUCTION IN PART OR WHOLE WITHOUT THE WRITTEN PERMISSION OF NorthStar Battery Company, LLC IS PROHIBITED.

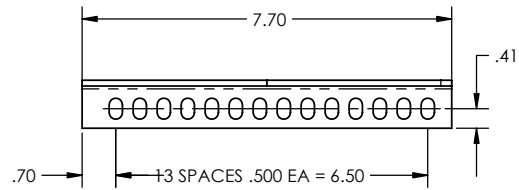
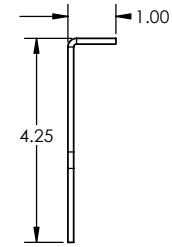
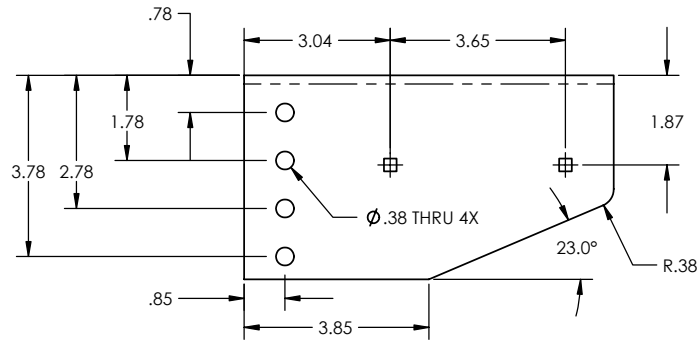

PROPRIETARY INFORMATION

Issue Date: 02/07/2005 PG 1 of 6 ECO 479-S04
 NSB PT NO 10RCK0004 DOC CODE: DWG-514-04

ITEM NO.	PART OR IDENTIFYING NO.	NOMENCLATURE OR DESCRIPTION	MATERIAL SPECIFICATION	QTY REQD.
UNLESS OTHERWISE SPECIFIED DIMENSIONS ARE IN INCHES FRACTIONS DECIMALS ANGLES XXX/XXX .XX + .1 XXX+XXX		CAD GENERATED DRAWING. DO NOT MANUALLY UPDATE		
MATERIAL		APPROVALS	DATE	
NSB-#		DRAWN	6-4-03	
NEXT ASSY USED ON		CHECKED	JWH	
APPLICATION		REP ENG		
		MFG ENG		
		QUAL ENG		
		SCALE		
		CAD FILE		
		DRAWG. NO. RCK0004		
		SHEET 3 OF 6		



RACK MOUNT, RT RACK BRACKET

THE INFORMATION CONTAINED IN THIS DRAWING IS THE SOLE PROPERTY OF NorthStar Battery Company, LLC. ANY REPRODUCTION IN PART OR WHOLE WITHOUT THE WRITTEN PERMISSION OF NorthStar Battery Company, LLC IS PROHIBITED.

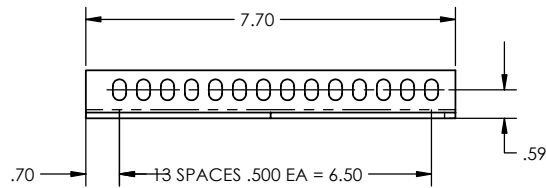
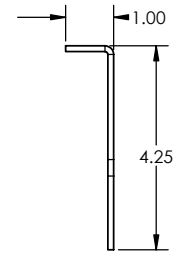
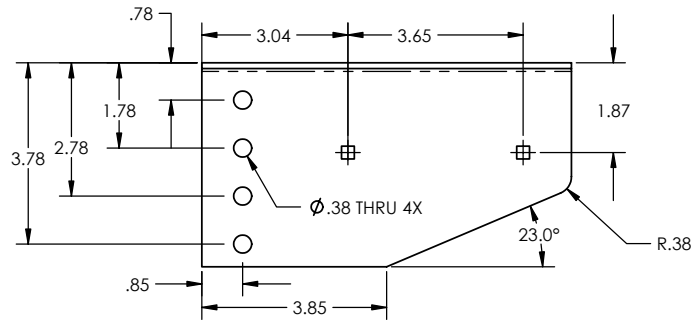

PROPRIETARY INFORMATION

Issue Date: 02/07/2005 PG 1 of 6 ECO 479-S04
 NSB PT NO 10RCK0004 DOC CODE: DWG-514-04

ITEM NO.	PART OR IDENTIFYING NO.	NOMENCLATURE OR DESCRIPTION	MATERIAL SPECIFICATION	QTY REQD.
UNLESS OTHERWISE SPECIFIED DIMENSIONS ARE IN INCHES		CAD GENERATED DRAWING, DO NOT MANUALLY UPDATE		
TOLERANCES ARE: FRACTIONS DECIMALS ANGLES XXX+XX +1 XXX-XXX		APPROVALS	DATE	
MATERIAL		CHECKED	DRAWN	
NSB-#		RESP ENG	6-4-03	
NEXT ASSY USED ON		MFG ENG		
APPLICATION		QUAL ENG		
DO NOT SCALE DRAWING		SCALE		
		CAD FILE		
		SHEET 4 OF 4		



RACK MOUNT, LT RACK BRACKET

DWG. NO: RCK0004

THE INFORMATION CONTAINED IN THIS DRAWING IS THE SOLE PROPERTY OF NorthStar Battery Company, LLC. ANY REPRODUCTION IN PART OR WHOLE WITHOUT THE WRITTEN PERMISSION OF NorthStar Battery Company, LLC IS PROHIBITED.

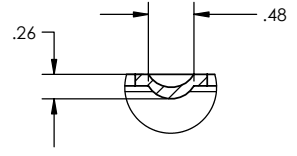
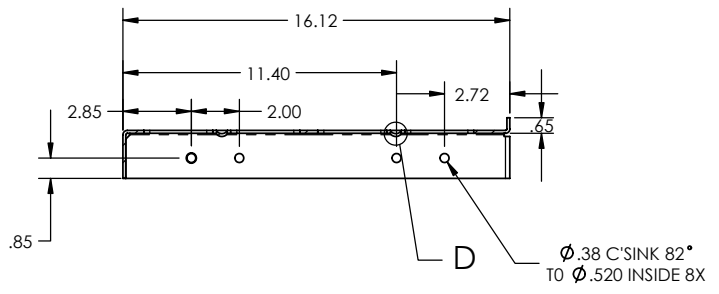
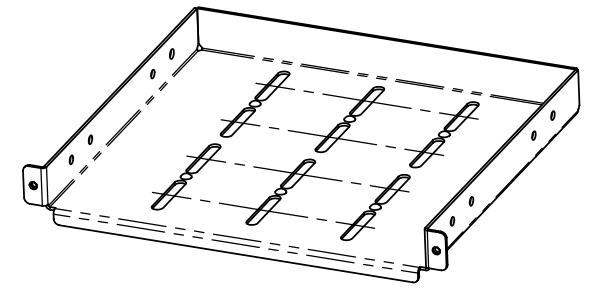
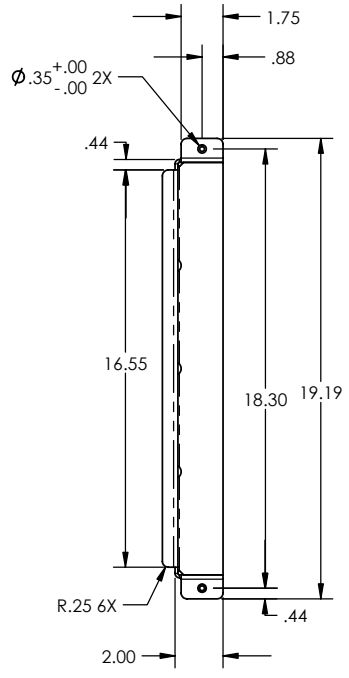
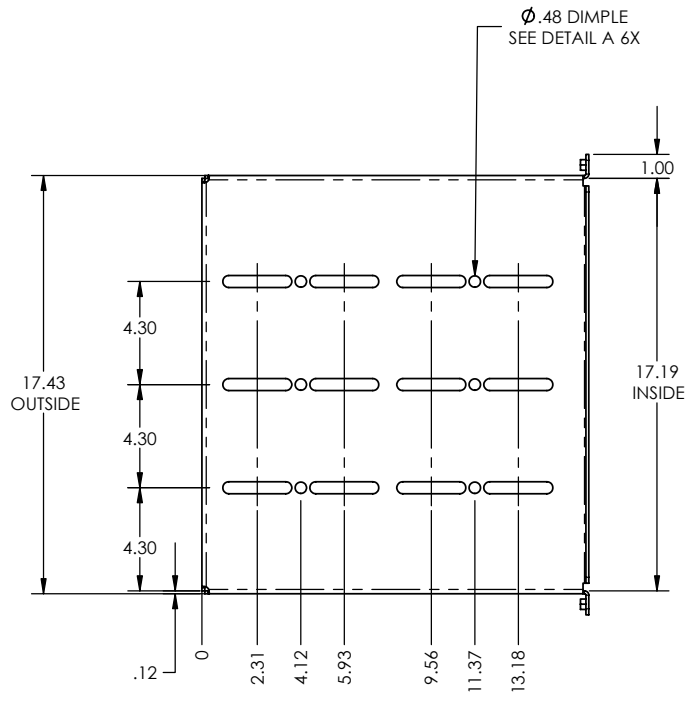

PROPRIETARY INFORMATION

Issue Date: 02/07/2005 PG 1 of 6 ECO 479-S04
NSB PT NO 10RCK0004 DOC CODE: DWG-514-04

ITEM NO.	PART OR IDENTIFYING NO.	NOMENCLATURE OR DESCRIPTION	MATERIAL SPECIFICATION	QTY REQD.
UNLESS OTHERWISE SPECIFIED DIMENSIONS ARE IN INCHES FRACTIONS DECIMALS ANGLES XXX/XXX XX + 1 XXX.XXX		CAD GENERATED DRAWING. DO NOT MANUALLY UPDATE		
MATERIAL		APPROVALS	DATE	
NSB-#		DRAWN JWH	6-4-03	
NEXT ASSY USED ON		CHECKED		
APPLICATION		RESP ENG		
DO NOT SCALE DRAWING		MFG ENG		
		QUAL ENG		
SCALE			DWG. NO. RCK0004	
CAD FILE			SHEET 5 OF 6	



19" RACK MOUNT, BATTERY SHELF

THE INFORMATION CONTAINED IN THIS DRAWING IS THE SOLE PROPERTY OF NorthStar Battery Company, LLC. ANY REPRODUCTION IN PART OR WHOLE WITHOUT THE WRITTEN PERMISSION OF NorthStar Battery Company, LLC IS PROHIBITED.

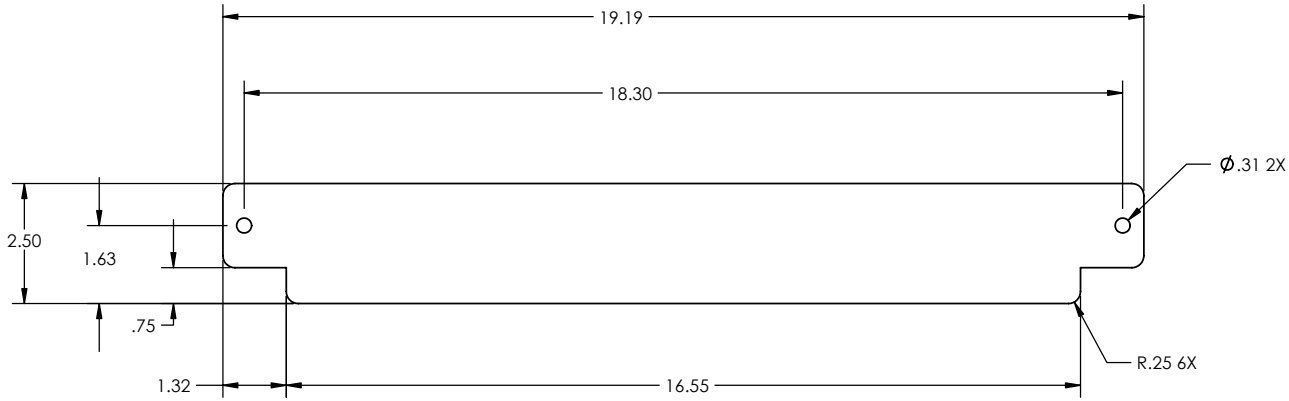

PROPRIETARY INFORMATION

Issue Date: 02/07/2005 PG 1 of 6 ECO 479-S04
 NSB PT NO 10RCK0004 DOC CODE: DWG-514-04

ITEM NO.	PART OR IDENTIFYING NO.	NOMENCLATURE OR DESCRIPTION	MATERIAL SPECIFICATION	QTY REQD.
UNLESS OTHERWISE SPECIFIED DIMENSIONS ARE IN INCHES		CAD GENERATED DRAWING, DO NOT MANUALLY UPDATE		
TOLERANCES ARE:		APPROVALS	DATE	
FRACTIONS DECIMALS ANGLES		DRAWN JWH	6-4-03	
+ .004 .004 .004 + .1				CHECKED
MATERIAL		RESP ENG		
NSB-#		MFG ENG		
NEXT ASSY USED ON		QUAL ENG		
APPLICATION		DO NOT SCALE DRAWING		
		SCALE	CAD FILE	SHEET # OF #



19" RACK MOUNT, BATT. SHELF PLATE

DWG. NO: RCK0004